

OA 217-6C

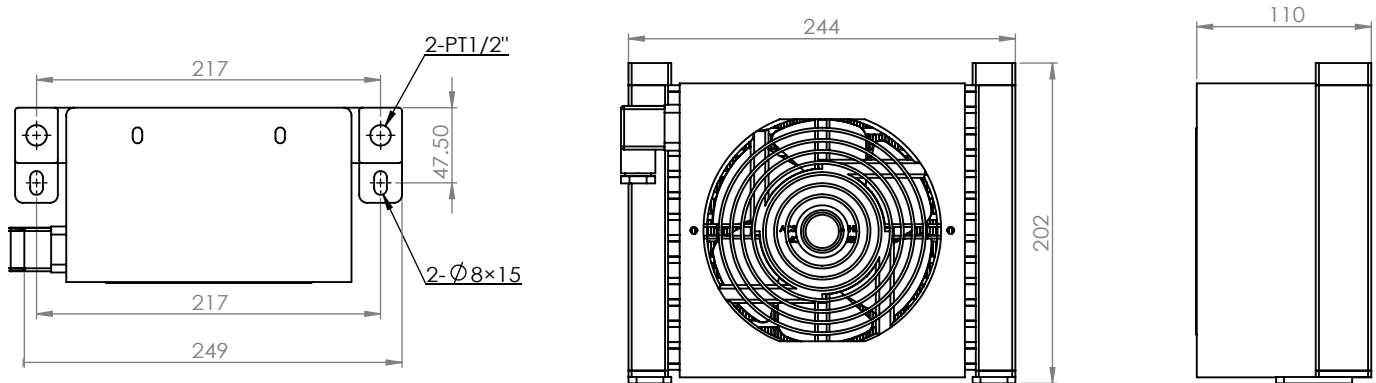

TYPE	OIL FLOW (ℓ/min)	VOLTAGE (V)	FREQUENCY (Hz)	CURRENT (A)	INPUT (W)	SPEED (r/min)	AIR FLOW (CFM)	NOISE dB(A)	certificate
OA217-6A1	1~15	1Ø110V	50/60	0.6/0.5	39.6/33.0	2600/3100	190/235	48	CE
OA217-6A2	1~15	1Ø220V	50/60	0.27/0.23	35.6/30.4	2600/3100	190/235	48	CE
OA217-6A3	1~15	1Ø380V	50/60	0.16/0.14	36.5/31.9	2600/3100	190/235	48	CE
OA217-6D1	1~15	DC12V		1.20	14.4	3000	235	51	CE
OA217-6D2	1~15	DC24V		0.75	18.0	3400	258	51	CE

OA 217-6C

