

DVQ2215

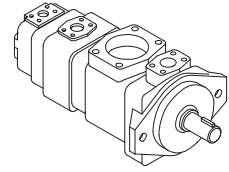

DVQ2215 - 65 - 38 - 17 - F - R - A A A A - 01 - 02

① ② ③ ④ ⑤ ⑥ ⑦ ⑧ ⑨ ⑩ ⑪ ⑫

- ① Series Number
型號
- ② P1:Discharge Port
Shaft End c.c/rev
P1出油口(從心軸方向看)
- ③ P2:Discharge Port
Shaft End c.c/rev
P2出油口
- ④ P3:Discharge Port
Shaft End c.c/rev
P3出油口(從封蓋方向看)
- ⑤ Mounting Type
安裝方式
F:Flange Type 法蘭型
L:Foot Type 腳座型
- ⑥ Shaft Rotation
(view from Shaft End)
轉向(從心軸方向看)
R:Clockwise 順時針
L:Anti-Clockwise 反時針
- ⑦ Discharge Port Position
(P1) Shaft End Pump
(view from Shaft End)
P1出油口(從心軸方向看)
- ⑧ Suction Port Position
(view from Shaft End)
進油口(從心軸方向看)
- ⑨ Discharge Port Position
(P2) Shaft End Pump
(view from Shaft End)
P2出油口(從心軸方向看)
- ⑩ Discharge Port Position
(P3) Shaft End Pump
(view from Shaft End)
P3出油口(從心軸方向看)
- ⑪ Shaft Type 01
心軸種類
- ⑫ Port connection variables 02
(P3)出油口種類

出入油口方向：	
A:	Upward (normal) 向上
B:	Downward 向下
R:	Right Hand 右邊
L:	Left Hand 左邊

P3	型式	A	B	C
	01	38.1	17.5	∅ 15
	02	47.6	22.2	∅ 19.05

Model 型號	Deliver Flow (ℓ/min) at no-load pressure 無負壓的傳輸流量					Running Speed (rpm) 轉速		Max Pressure (Kgf/cm ²) 最高壓力	
	Running Speed (rpm) 轉速					Max 最大	Min 最小	Cont.	Peak.
	1000	1200	1500	1800					
VQ15 (P3)	06	6.2	7.4	9.3	11.2	1800	800	210	240
	08	8.1	9.7	12.1	14.6	1800	800	210	240
	11	11.2	13.4	13.4	20.1	1800	800	210	240
	14	14.3	17.1	21.5	25.7	1800	800	210	240
	17	17.1	20.5	25.6	30.7	1800	800	210	240
	19	19.2	23.0	28.8	34.5	1800	800	210	240
	23	23.3	27.9	34.9	41.9	1800	800	210	240
	26	26.1	31.3	39.1	46.9	1800	800	210	240
	31	31.1	37.3	46.6	—	1500	800	175	240
DVQ20 (P2)	06	6.2	7.4	9.3	11.2	1800	800	210	260
	08	8.1	9.7	12.1	14.6	1800	800	210	260
	11	11.2	13.4	13.4	20.1	1800	800	210	260
	14	14.3	17.1	21.5	25.7	1800	800	210	260
	17	17.1	20.5	25.6	30.7	1800	800	210	260
	19	19.2	23.0	28.8	34.5	1800	800	210	260
	23	23.3	27.9	34.9	41.9	1800	800	210	260
	26	26.1	31.3	39.1	46.9	1800	800	210	260
	32	32.1	38.3	47.6	—	1500	800	175	240
	34	34.1	40.8	50.4	—	1500	800	175	240
DVQ25 (P1)	38	38.1	45.9	—	—	1200	800	175	240
	44	44.1	52.9	—	—	1200	800	175	210
	18	18.1	21.7	27.2	32.6	1800	800	210	260
	22	22.1	26.5	33.3	39.8	1800	800	210	260
	26	26.2	31.4	39.3	47.1	1800	800	210	260
	32	32.1	38.5	48.1	57.7	1800	800	210	260
	38	38.2	45.8	57.3	68.7	1800	800	210	260
	43	43.2	51.8	64.8	77.7	1800	800	210	260
	47	47.1	56.5	70.0	85.0	1800	800	210	260
	52	52.3	62.7	78.4	94.1	1800	800	210	260
60	60.2	72.7	90.3	108.3	1800	800	210	260	
65	65.3	78.3	97.9	117.5	1800	800	210	230	
75	75.0	90.0	112.5	—	1500	800	210	230	

DVQ2215

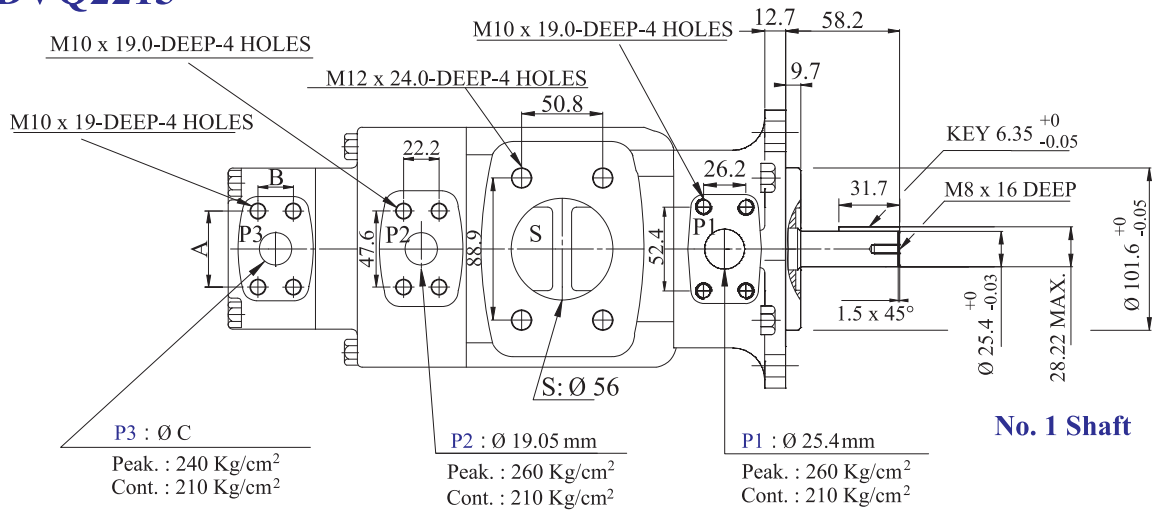

P3	型式	A	B	C
	01	38.1	17.5	Ø 15
02	47.6	22.2	Ø 19.05	

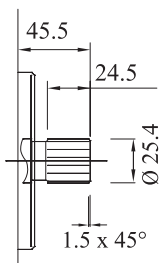
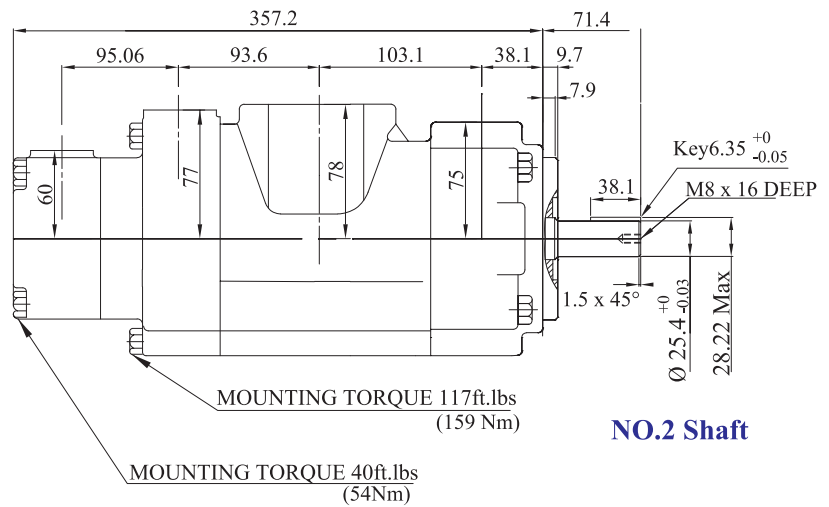
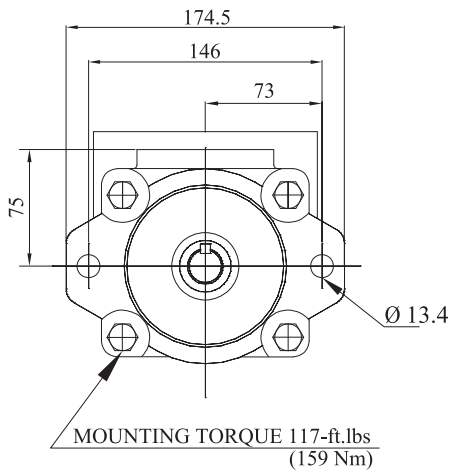

NO.3 Shaft

SAE BB
Splined shaft
Class 1-J498 b 16/32d.p.
-15 teeth 30° pressure
angle flat root side fit

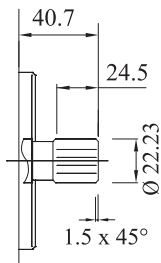

NO.5 Shaft

SAE B splined shaft
Class 1-J498 b 16/32d.p.
-13 teeth 30° pressure
angle flat root side fit

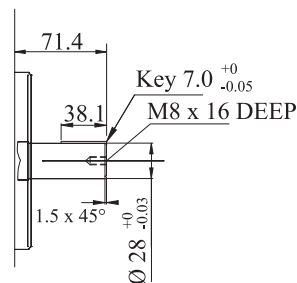

NO.6 Shaft

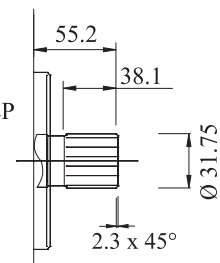

NO.7 Shaft

splined shaft Class
1-J498 b 12/24 d.p.
-14 teeth 30° pressure
angle flat root side fit