

"Tail-Gate" Hydraulic Schematic (A)

"Tail-Gate" Hydraulic Schematic (B)

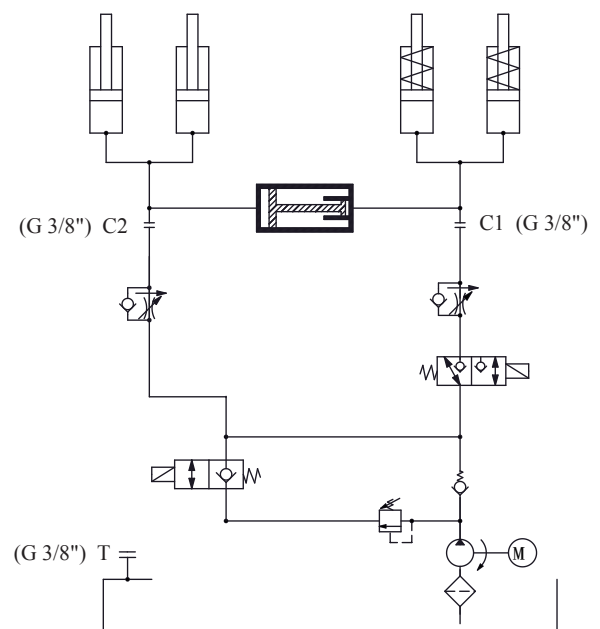
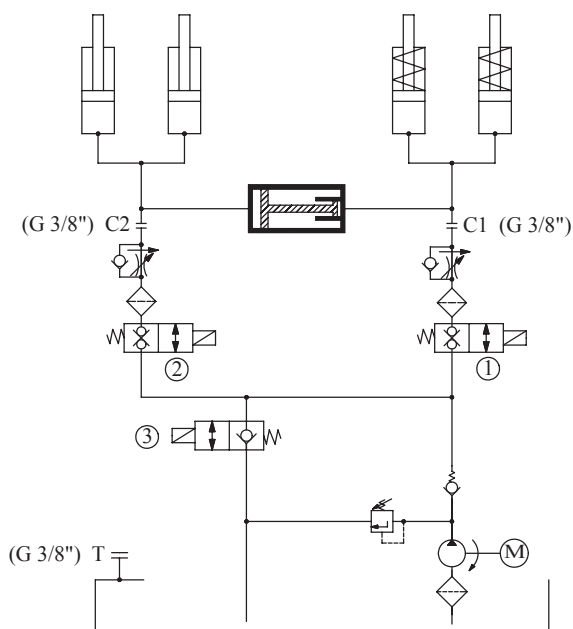

The TG-168 series power pack is designed for "Tail-Gate of the truck" application, which includes the unit and complete components of a power protecting cover, therefore users just need to connect the fittings and control wires.

This compact design supplies customers:

- ◆ Easy to install and service.
- ◆ Saves space and costs.
- ◆ High quality and quick delivery.

Before the power packs leave our factory they are fully inspected and tested by our QA/QC(ISO) team. If you have any questions or need a custom design, please feel free to contact us.