

OA 217-4C

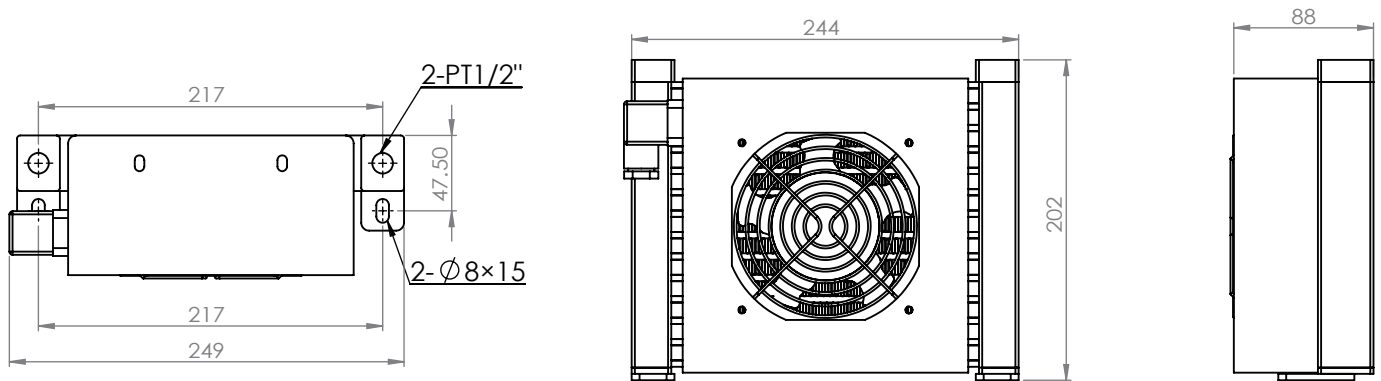

TYPE	OIL FLOW (ℓ/min)	VOLTAGE (V)	FREQUENCY (Hz)	CURRENT (A)	INPUT (W)	SPEED (r/min)	AIR FLOW (CFM)	NOISE dB(A)	certificate
OA217-4A1	1~15	1Ø110V	50/60	0.25/0.22	16.5/14.5	2600/3000	88/109	39	CE
OA217-4A2	1~15	1Ø220V	50/60	0.10/0.09	13.2/11.9	2600/3000	88/109	39	CE
OA217-4A3	1~15	1Ø380V	50/60	0.08/0.07	18.2/16.0	2600/3000	88/109	39	CE
OA217-4D1	1~15	DC12V		0.60	7.2	3000	130	45	CE
OA217-4D2	1~15	DC24V		0.32	7.7	3000	130	51	CE

OA 217-4C

