

MR Type

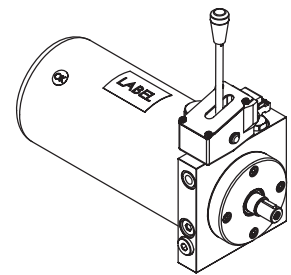

S Type

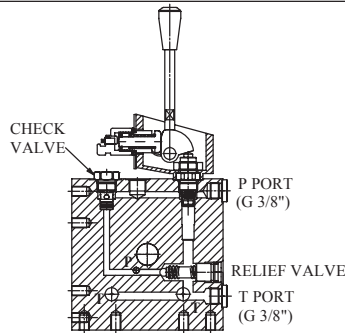
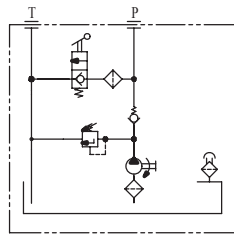
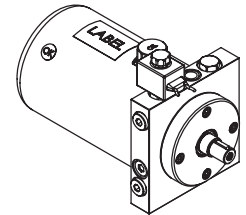
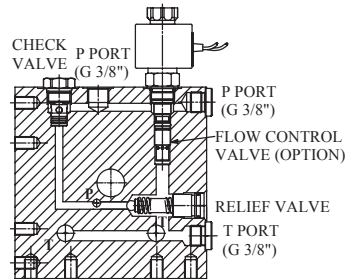
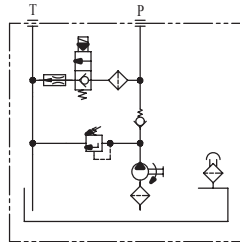

N Type

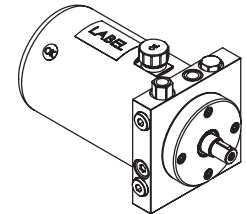
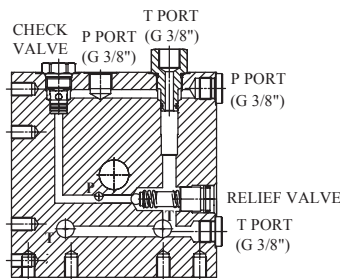
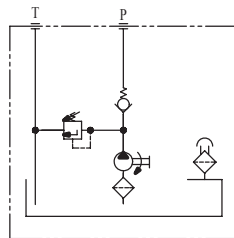

A Type

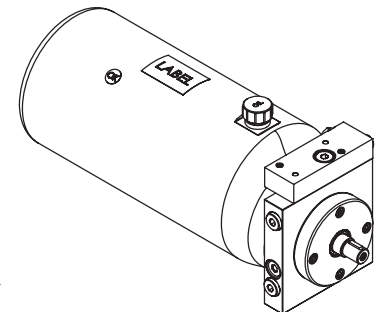
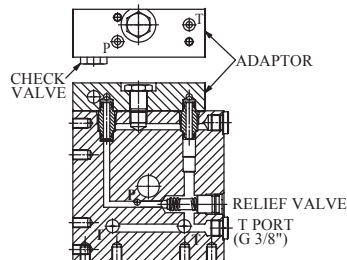
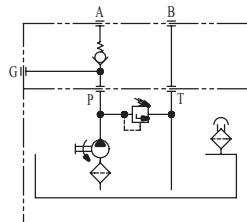

A Type + Cetop 03

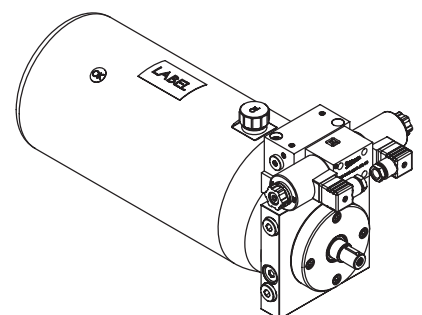
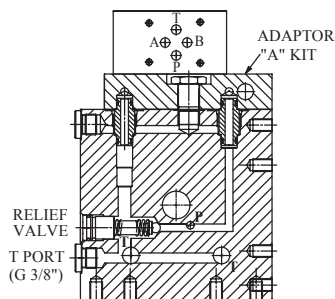
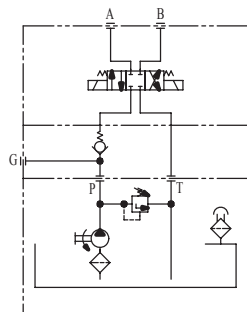

The W80BT power pack series is designed for use with belts powered by various engines. These power packs have been designed mostly for agricultural use, but can be used in other fields.

- ◆ Pump capacity range is from 0.5cc/rev to 7.3cc/rev.
- ◆ Standard tank sizes vary from 1.0L to 8.0L. Tailor made tanks are also available.
- ◆ Hydraulic circuit valves can be inter-changed with the standard manifold. Custom made circuits are also available.

Before the power packs leave our factory they are fully inspected and tested by our QA/QC (ISO 9001) team. If you have any questions or need a custom design, please feel free to contact us.