

### N Type

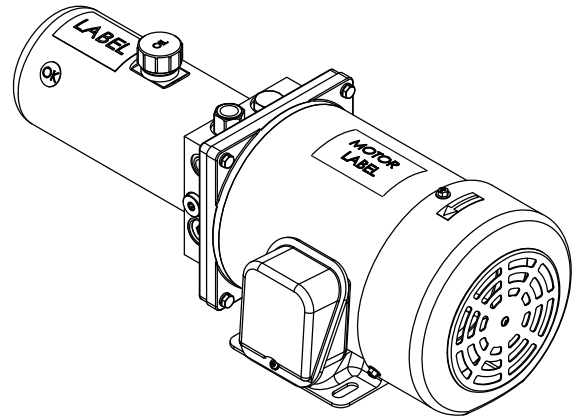

### S Type

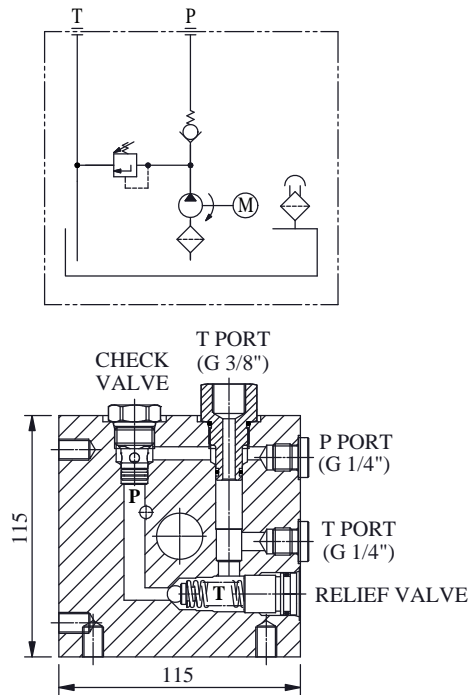
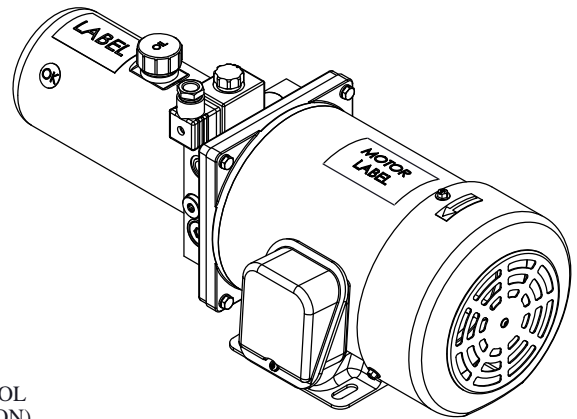
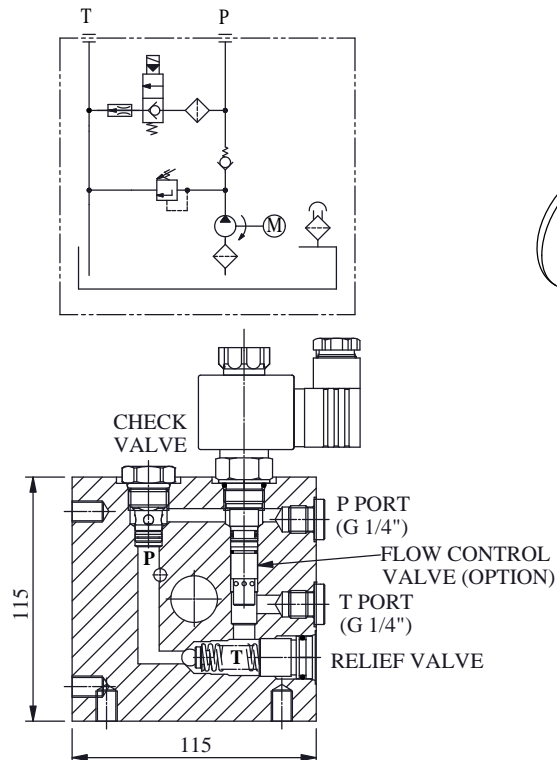

The W81A mini power pack series is designed for a wide range of applications which include;

- ◆ Our standard AC motors range from 0.25HP to 3.0HP.
- ◆ Tank sizes vary from 0.5L to 1.7L.
- ◆ Pump capacity range is from 0.5cc/rev to 7.3cc/rev.

The purpose for the mini design is to save space. The power pack is only 115mm by 115mm. If you have any questions or need a custom design, please feel free to contact us.