

- SRG 系列節流閥附止回閥之主要功能，是調整迴路速度。
- 當壓力幾乎固定，或是壓力變動，允許少量流量流動的情況下，使用此系列閥。
- Restrictor SRG series is to adjust the circuit speed.
- When pressure is fixed or changeable, it allows having a little flow by using this valve.



SRG-03

型號意義 How to order :

SR G - 06 - 15

1 2 3 4

1	系列號	Series
2	版式連接	SUB-Plate mounting
3	口徑代號	Valve size 06:3/4", 10:1-1/4"
4	中止閥	Stop valves

產品規格 Specification :

名稱 Name	口徑 Valve Size	型號 Model	最大流量 Max. Flow (ℓ/min)	重量 Weight (Kg)
節流閥 Restrictors valve	3/8	SRG-03	30	1.2
	3/4	SRG-06	85	2.2
	1-1/4	SRG-10	220	5.2
	3/8	SRG-03-15	30	1.2

附件 Attachment :

型號 Model	安裝螺絲 Mounting bolts	O 型環 O-Ring
SRG-03	M8 x 35L 4 支 piece	JIS B 2401-1B-P18 2 條 piece
SRG-06	M10 x 45L 4 支 piece	JIS B 2401-1B-P29 2 條 piece
SRG-10	M12 x 60L 4 支 piece	JIS B 2401-1B-P38 2 條 piece

圖形符號 Graphic symbol :



SRG

SRG-03.06

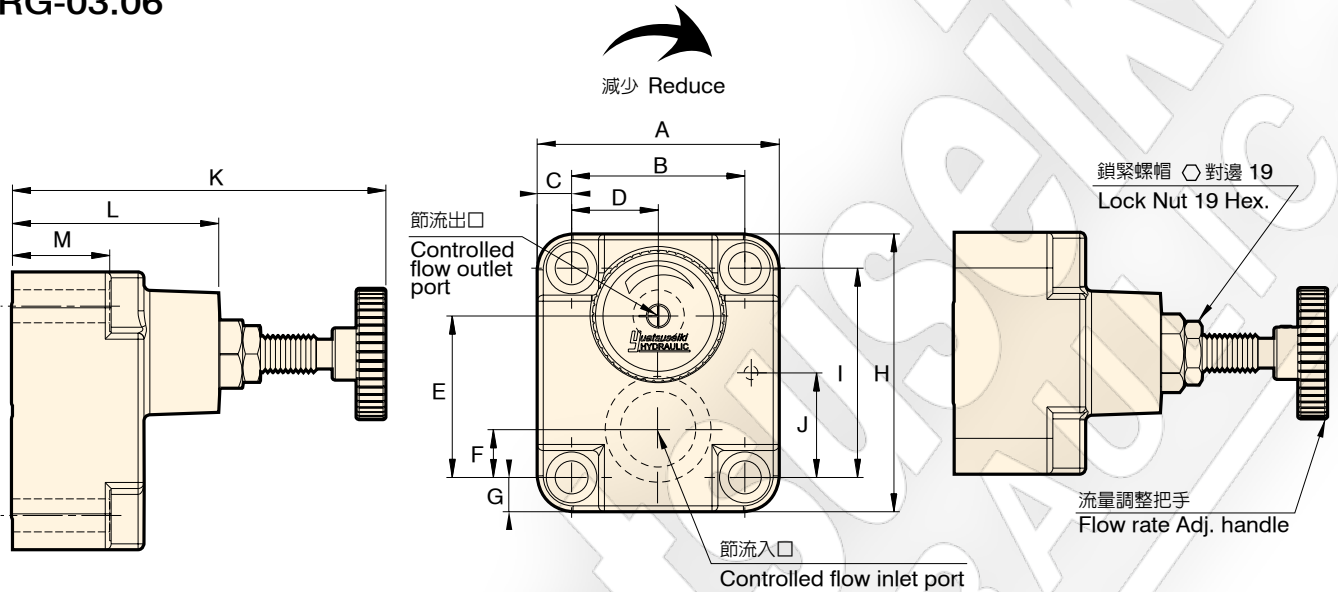

單位 Unit : mm

型號 Model	A	B	C	D	E	F	G	H	I	J	K	L	M
SRG-03	61	40	10.5	20	45	15	10.5	81	60	30	106	56	22
SRG-06	81	58	11.5	29	54	16	11.5	93	70	35	125	69	32.5

SRG-10

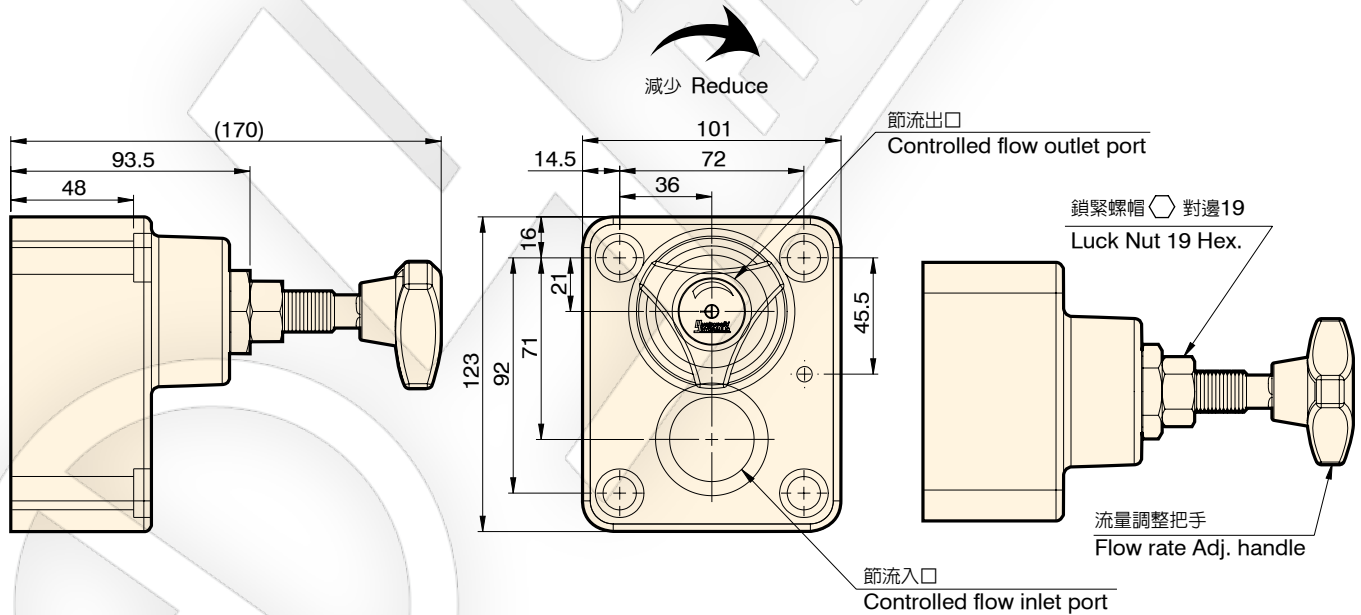

單位 Unit : mm

性能曲線圖 Performance curves

■ 流量-壓力特性曲線圖

The characteristic curve chart of Flow vs. Pressure

使用油：黏度 Test fluid viscosity: 35mm²/s{cSt}

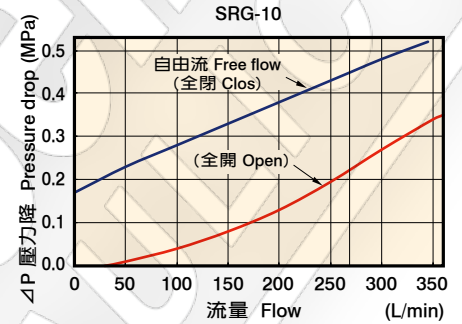
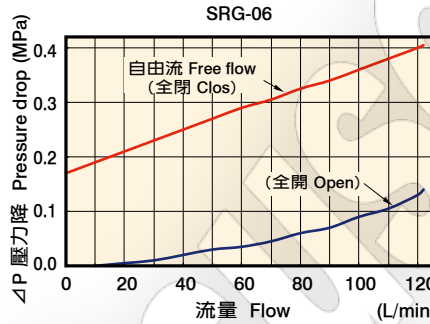
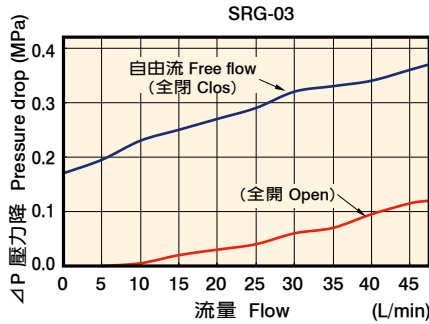

■ 流量-調整旋扭特性曲線圖

The characteristic curve chart of Flow vs ADJ. knob position

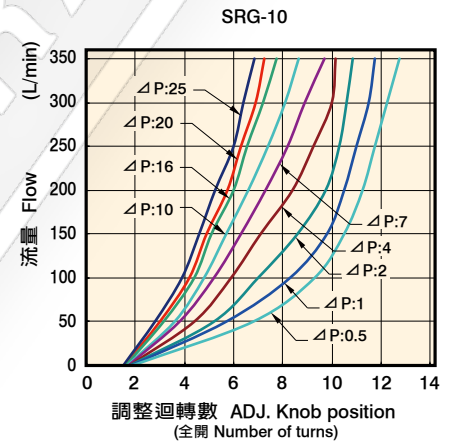
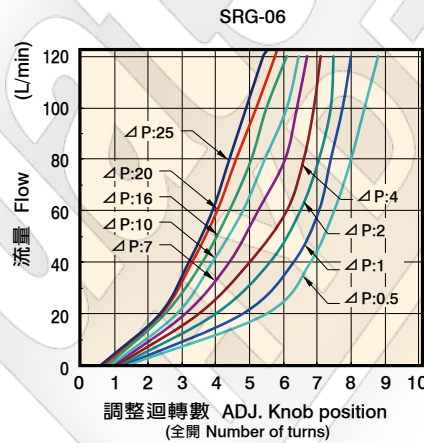
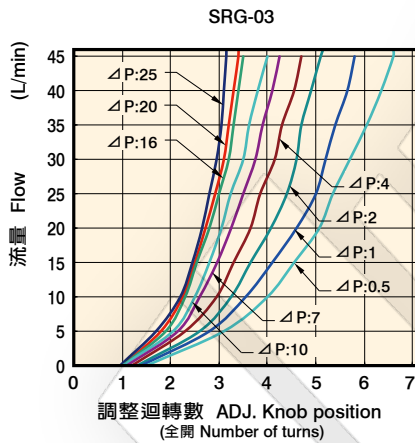

出入油標示 Inlet / outlet sign

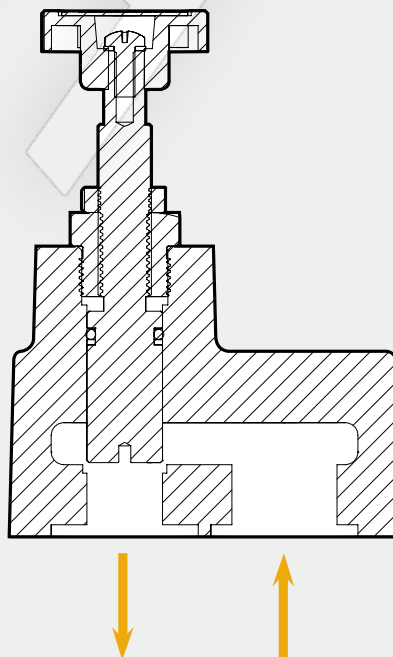

爆炸圖 How to order for a complete assembled valve

SRG-03.06.10

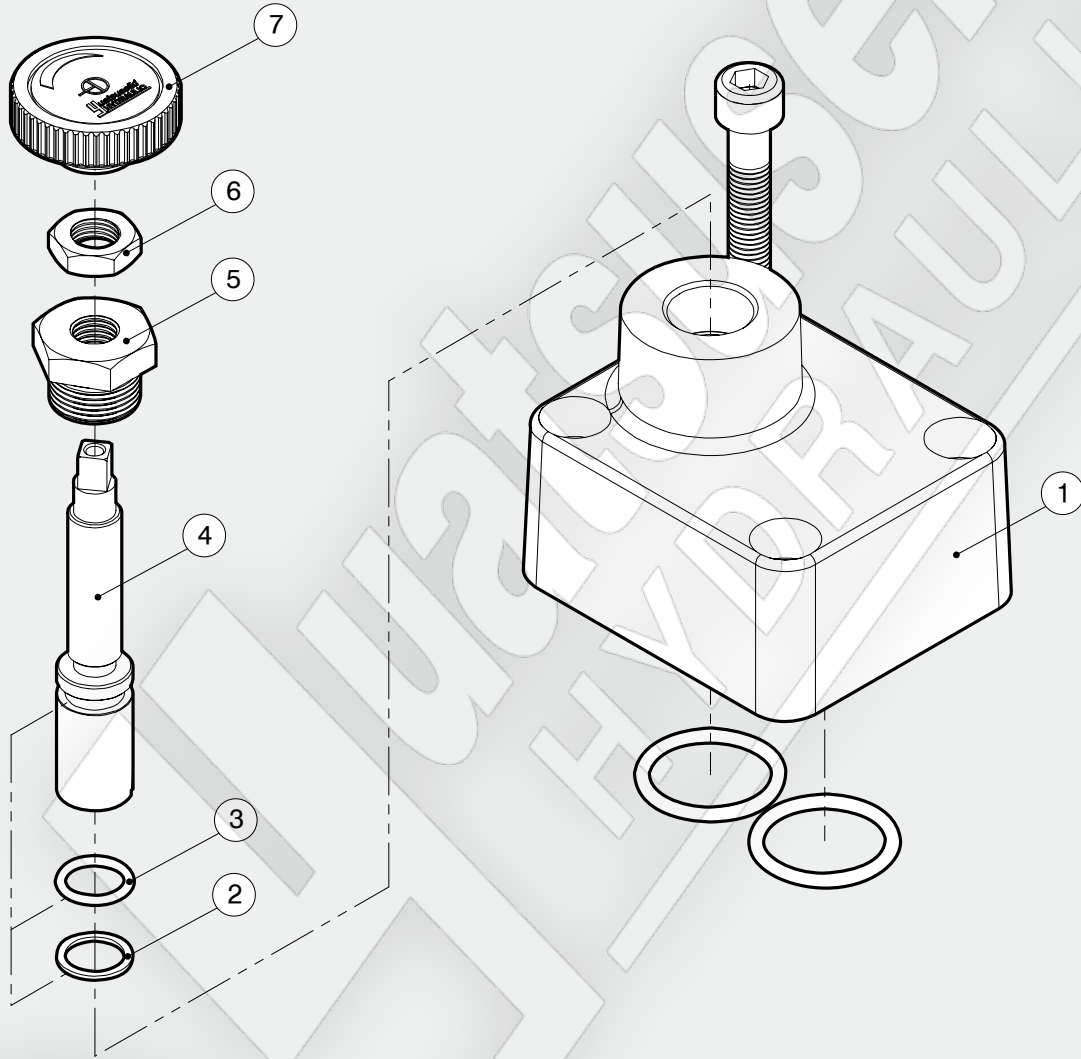

項次編號 No.	品名 Name of parts	數量 Q
1	本體 Body	1
2	SRG-03 JIS B 2401-1A-P10A	1
	SRG-06 JIS B 2401-1A-P14	1
	SRG-10 JIS B 2401-1A-P20	1
3	SRG-03 JIS B 2407-T2-P10A	1
	SRG-06 JIS B 2407-T2-P14	1
	SRG-10 JIS B 2407-T2-P20	1

項次編號 No.	品名 Name of parts	數量 Q
4	心軸 Spool	1
5	把手螺母 Nut	1
6	螺母 Nut	1
7	壓力調整把手 Pressure adj. handle	1