

VPKCF8
VPKCF12
VPKCF15
VPKCF20

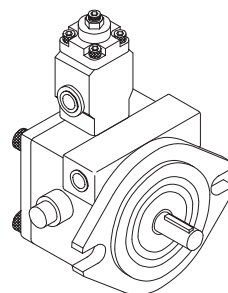

SYMBOL



FEATURES 特點

Model	Operating Pressure (Kgf/cm ²)		Rated Speed (rpm)		Net Weight
			MAX	MIN	
VPKCF8	A1: 5-18 A3:30-55	A2:15-35 A4:50-70	1800	800	4.8Kg
VPKCF12	A1: 5-18 A3:30-55	A2:15-35 A4:50-70	1800	800	4.8Kg
VPKCF15	A1: 5-18 A3:30-55	A2:15-35 A4:50-70	1800	800	5.2Kg
VPKCF20	A1: 5-18 A3:30-55	A2:15-35 A4:50-70	1800	800	5.2Kg

ORDERING CODE 訂購指引

VPKC-F*A*-01-A

① ②③ ④ ⑤ ⑥

- ① — Series Number
- ② — Flange Type
- ③ — Output Flow at 1800rpm
8,12,15,20 (ℓ/min)
- ④ — Pressure Adjusting Range
1:5-18 2:15-35
3:30-55 4:50-70 (Kgf/cm²)
- ⑤ — Shaft Type
01:No.01 Shaft
02:No.02 Shaft
- ⑥ — Type of Suction Port & Discharge Port
A or No Marking: PT
B: NPT
C: SAE
D: BSP

VPKCF12

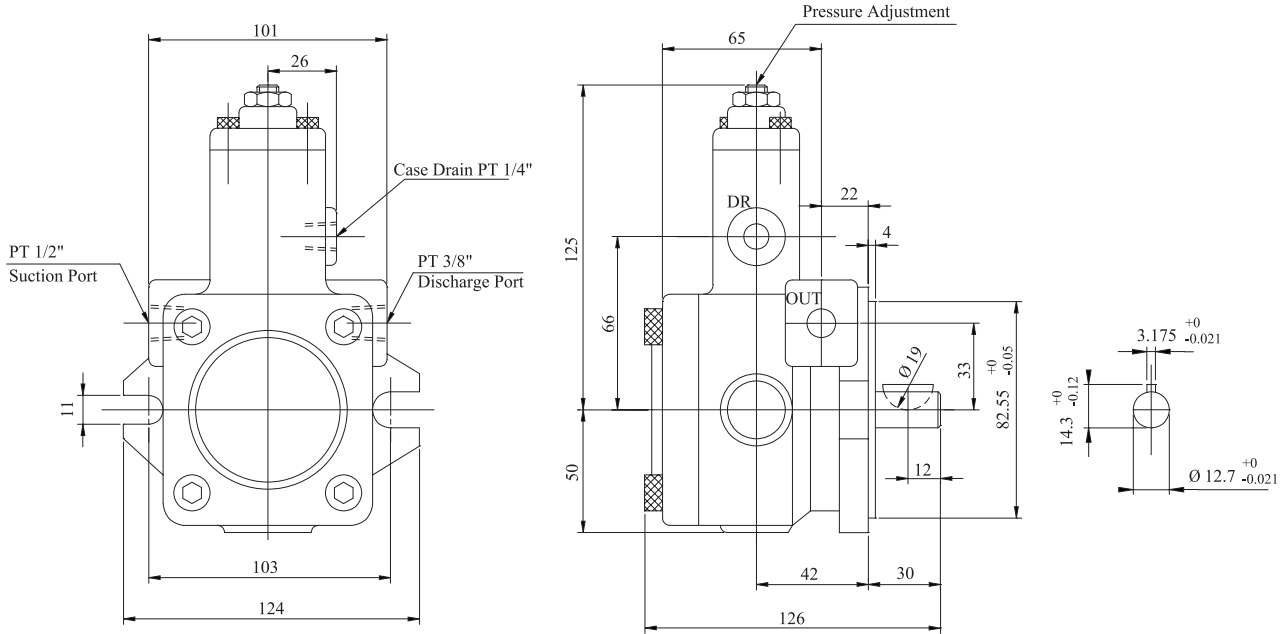

VPKCF20

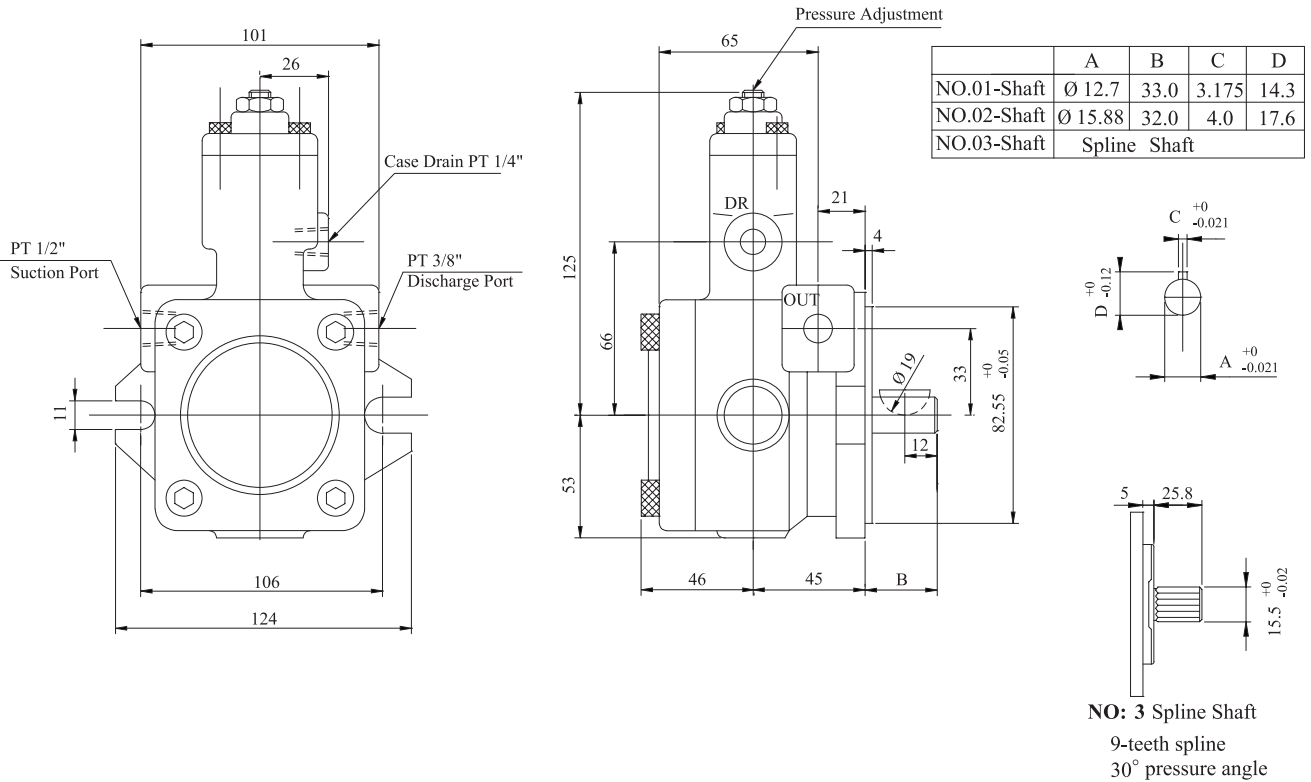

VPKCF8

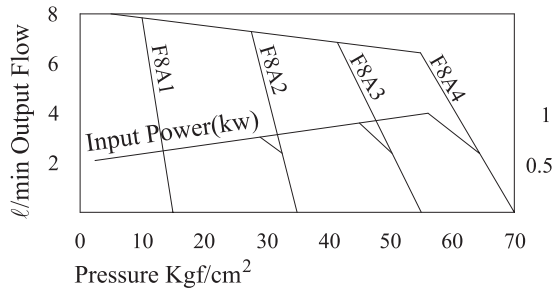

VPKCF12

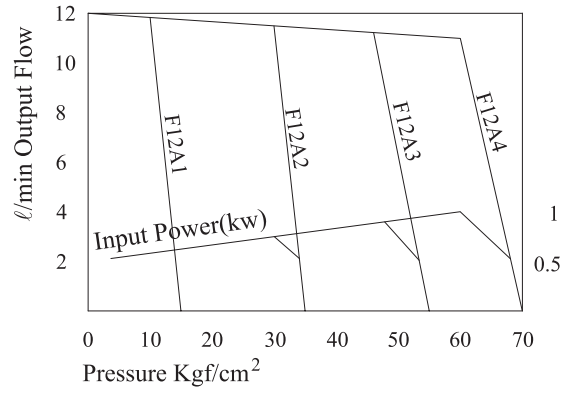

VPKCF15

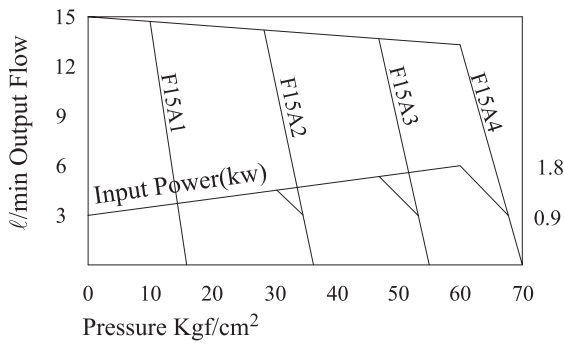

VPKCF20

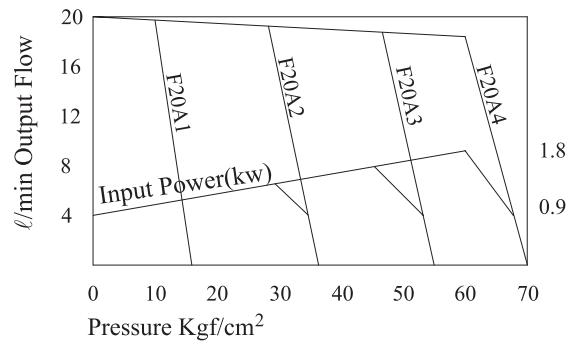

VPKCF30

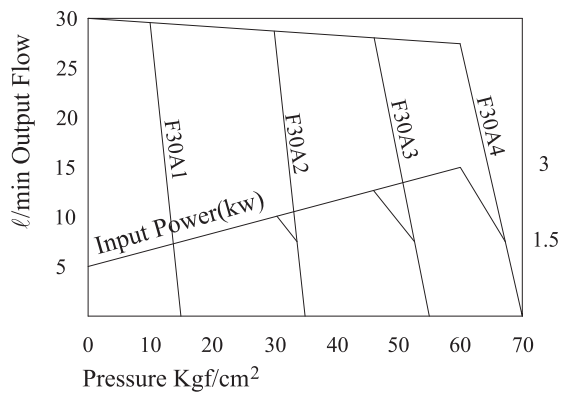

VPKCF40

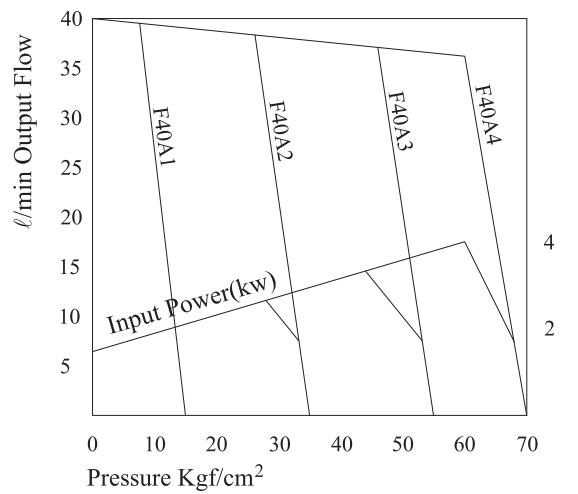

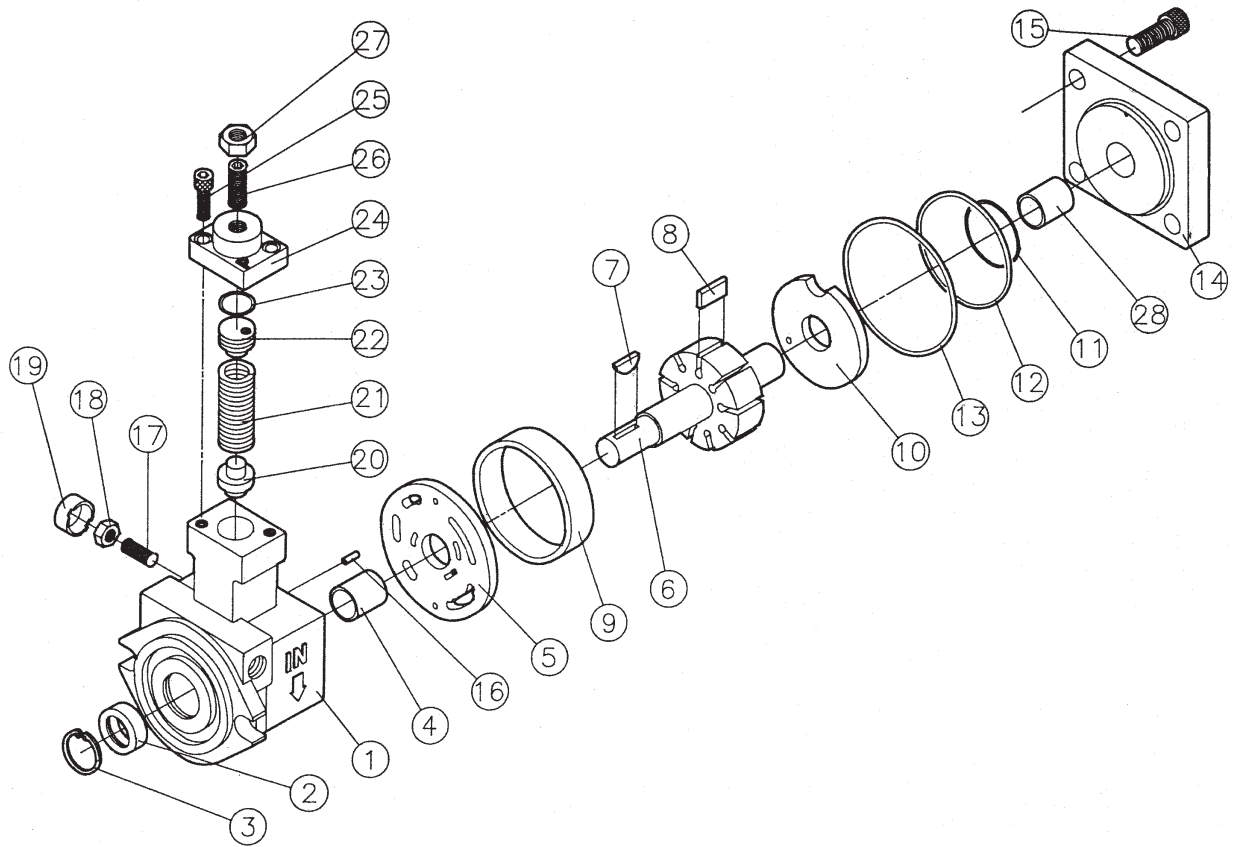

VPKC Single Pump Parts List VPKC (F8、F12、F15、F20)系列單泵零件表

- | | |
|----------------------------|--|
| NO.1 Housing (體) | NO.17 O - Ring + Slide Screw (O型環+調中心螺絲) |
| NO.2 Seal (油封) | NO.18 Nut (螺帽) |
| NO.3 Retainer Ring (扣環) | NO.19 Protect Cover (保護蓋) |
| NO.4 Engine Bush (乾式軸承) | NO.20 Piston (雙頭活塞) |
| NO.5 Port Plate A (壓力板 A) | NO.21 Spring (彈簧) |
| NO.6 Rotor (轉子) | NO.22 Spring Retainer (彈簧承座) |
| NO.7 Woodruff Key (半圓鍵) | NO.23 O - Ring (O型環) |
| NO.8 Vanes (葉片) | NO.24 Cover (側蓋) |
| NO.9 Cam Ring (軸環) | NO.25 Socket Head Cap-Screw (側蓋螺絲) |
| NO.10 Port Plate B (壓力板 B) | NO.26 Socket Set Screw (調壓螺絲) |
| NO.11 O - Ring (O型環) | NO.27 Nut (螺帽) |
| NO.12 O - Ring (O型環) | |
| NO.13 O - Ring (O型環) | |
| NO.14 Cover (蓋) | |
| NO.15 Cap-Screw (上蓋螺絲) | |
| NO.16 Lock Pin (定位銷) | |