

MR & MK Type

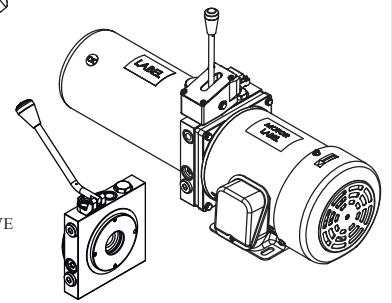

S Type

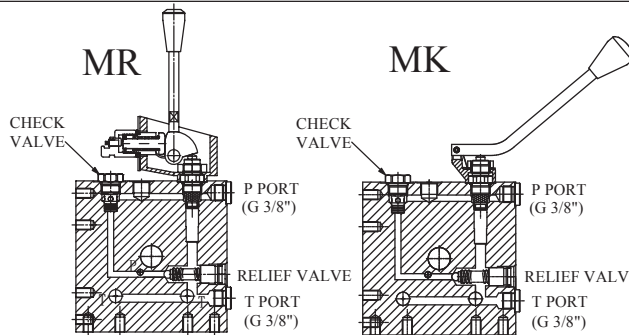
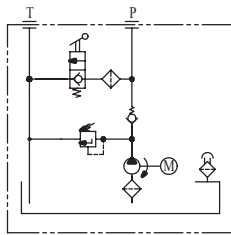
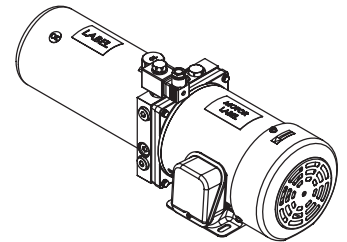
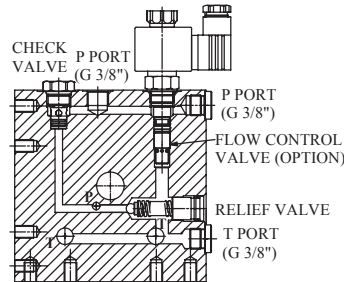
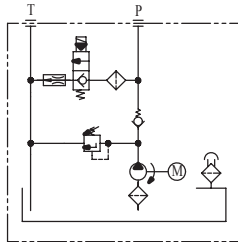

N Type

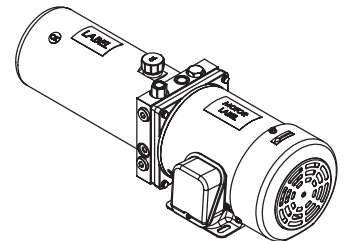
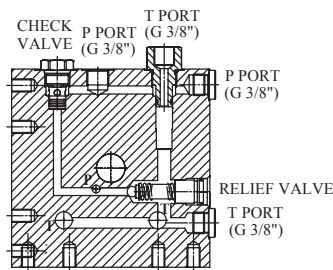
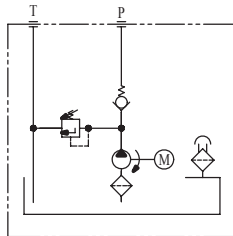

A Type

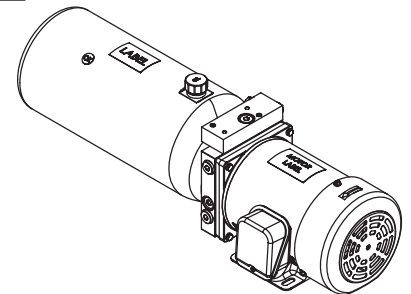
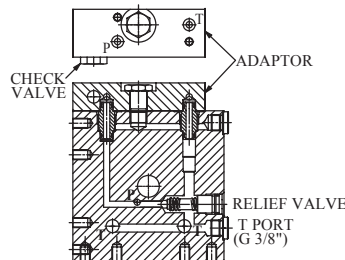
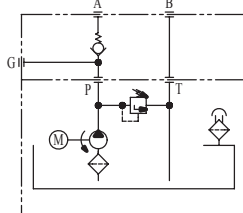

A Type + Cetop 03

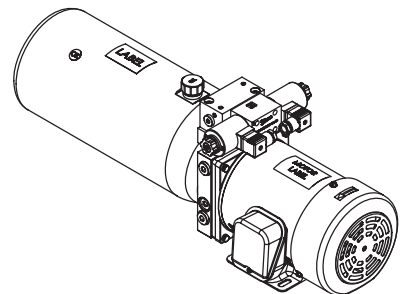
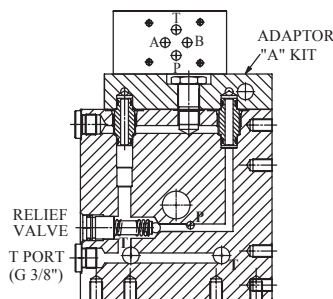
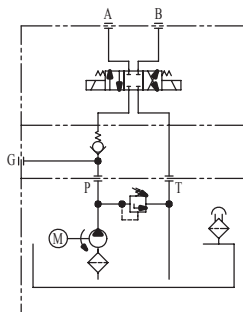

The W80A series power pack is designed for a wide range of applications which include;

- ◆ Our standard AC motors range from 0.25HP to 3.0HP.
- ◆ Pump capacity range is from 0.5cc/rev to 7.3cc/rev.
- ◆ Standard tank sizes vary from 1.0L to 8.0L. Tailor made tanks are also available.
- ◆ Hydraulic circuit valves can be inter-changed with the standard manifold. Custom made circuits are also available.

Before the power packs leave our factory they are fully inspected and tested by our QA/QC(ISO 9001) team. If you have any questions or need a custom design, please feel free to contact us.