

HGP-53A

- ▶ Max. Pressure : 300 kgf/cm²
(4200psi)
- ▶ Flange : SAE 2-bolt, DIN 4-bolt

ORDER CODES

HGP-53A -
 F -
 75 -
 R -
 X -
 2B

1
 2
 3
 4
 5
 6

1 Model Name	HGP-53A	
2 Mounting	F	flange type
	L	foot type
3 Delivery Capacity	22, 26, 33, 44, 48, 55, 63, 75, 80, 90	
4 Rotation Direction	R	clockwise
	L	counter - clockwise
5 Shaft Type	X	straight shaft
	Y	spline shaft
	Z	taper shaft
6 Flange Mounting Type	2B	SAE 2-bolt
	4BD	DIN 4-bolt

SCHEMATIC SYMBOL

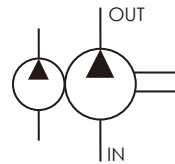

SPECIFICATIONS

Model	Accurate Displacement Capacity (cc/rev)	Operational Pressure (kgf/cm ²)	Max. Pressure (kgf/cm ²)	Speed (r.p.m.)		Weight (kg)
				Loading	Unloading	
HGP-53A-22	22+3A	It depends on the 3A that meet your needs.	It depends on the 3A that meet your needs.	3000	700	7.6 ~ 10.5
HGP-53A-26	26+3A			3000	700	
HGP-53A-33	33+3A			3000	700	
HGP-53A-44	44+3A			3000	700	
HGP-53A-48	48+3A			3000	700	
HGP-53A-55	55+3A			3000	700	
HGP-53A-63	63+3A			3000	600	
HGP-53A-75	75+3A			3000	600	
HGP-53A-80	80+3A			3000	600	
HGP-53A-90	90+3A			2500	600	

DIMENSIONS (unit : mm)

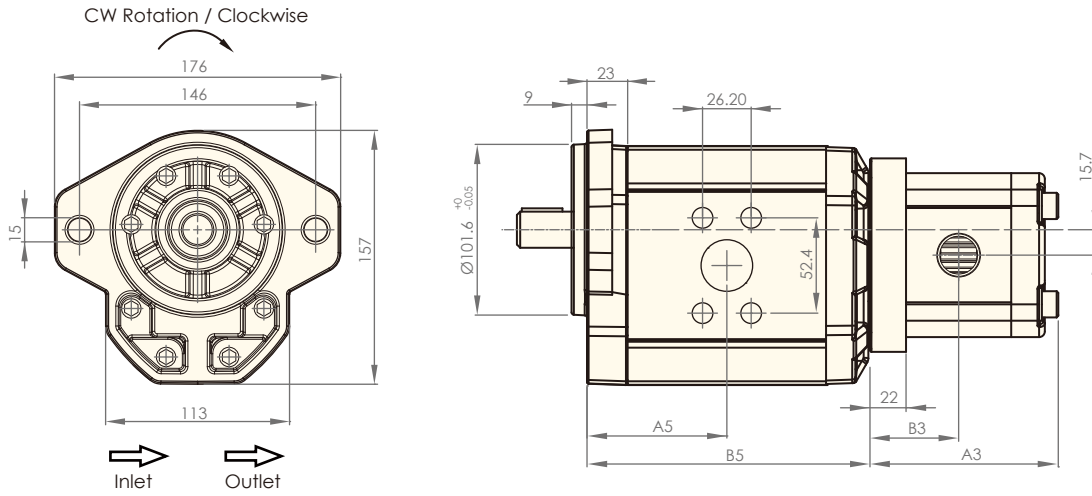
HGP-53A-X-2B

Model	A5	B5
HGP-5A-2B-22	56.5	117
HGP-5A-2B-26	58.5	121
HGP-5A-2B-33	61	126
HGP-5A-2B-44	65	134
HGP-5A-2B-48	66.5	137
HGP-5A-2B-55	69	142
HGP-5A-2B-63	71	146
HGP-5A-2B-75	76	156
HGP-5A-2B-80	78	160
HGP-5A-2B-90	81.5	167

Model	A3	B3
HGP-3A-2	97.4	46.7
HGP-3A-3	99	47.5
HGP-3A-4	101	48.5
HGP-3A-6	105	50
HGP-3A-8	109	51.5
HGP-3A-11	113	54
HGP-3A-13	117	56
HGP-3A-14	119	57
HGP-3A-17	123	59
HGP-3A-19	127	61
HGP-3A-23	134	65
HGP-3A-25	137	66
HGP-3A-28	141	68
HGP-3A-30	145	70
HGP-3A-33	150	73
HGP-3A-35	154	75

* The dimension of shafts please refers to Page 29.
The dimension of inlet and outlet sizes please refer to Page 17 & 29.