

N Type

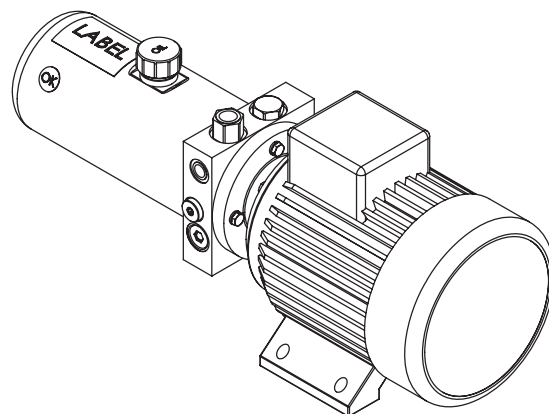

S Type

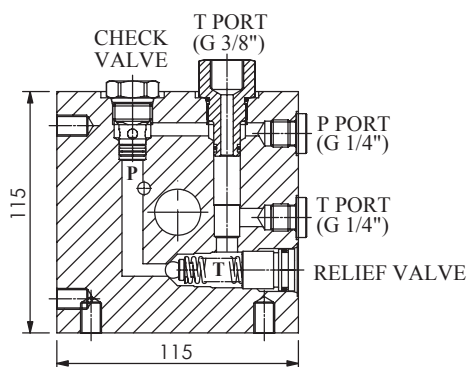
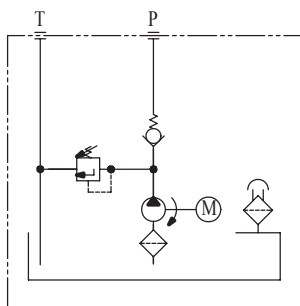
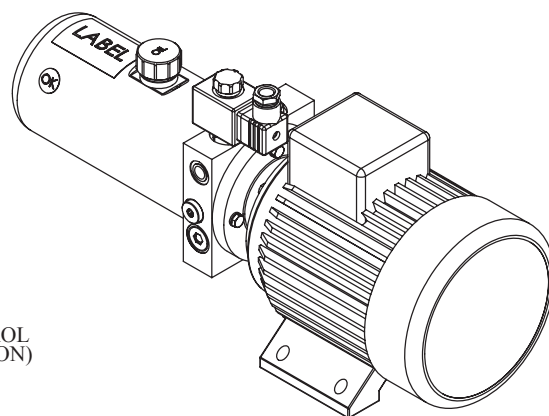
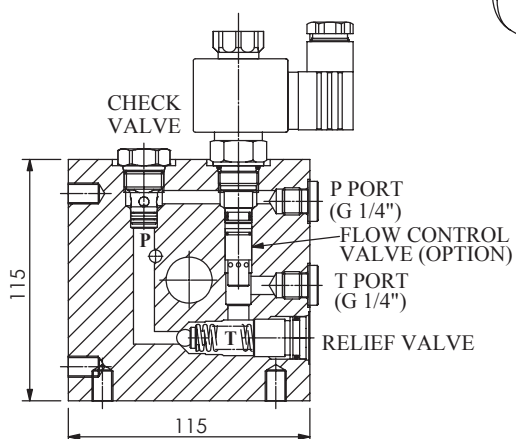
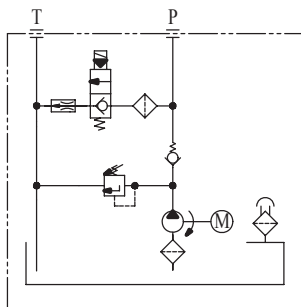

The W81AB mini power pack series is designed for use with European standard B14 AC motors.

- ◆ Standard frame sizes range from 63M to 112M.
- ◆ Tank sizes vary from 0.5L to 1.7L.
- ◆ Pump capacity range is from 0.5cc/rev to 7.3cc/rev.

The purpose for the mini design is to save space. The power pack is only 115mm by 115mm. If you have any questions or need a custom design, please feel free to contact us.