

# 流量控制閥 (減速閥附止回閥)

## FLOW CONTROL VALVE (Deceleration with check valve)

- 通過閥的流量，由凸輪操作的閥蕊調整，當閥蕊壓下時，在常開型閥中流量減小。它們主要用於控制機床或類似場合的執行元件的速度。
- The flow goes through the valve is adjusted by spool cam operated. When spool is pushed down, the flow with normally open is getting smaller. They are used to control the machine tool or the speed of actuator at similar places.



流量控制閥 減速閥附止回閥  
Flow Control Valve (Deceleration with check valve)

### 型號意義 How to order :

**CL T - 06 - O**

1 2 3 4

1 系列號	Series
2 G: 板式連接 / T: 管式連接	G: SUB-Plate mounting / T: Threaded connections
3 口徑代號	Valve size 03:3/8", 06:3/4"
4 O: 常開型-無記號 / N: 常閉型	O: Normally Open-NO code / N: Normally Closed

### 產品規格 Specification :

名稱 Name	口徑 Valve Size	型號 Model	最大流量 Max. Flow (ℓ/min)	重量 Weight (Kg)
減速閥附止回閥 Deceleration with check valve	3/8	CLT-03	30	5
	3/4	CLT-06	85	5
	3/8	CLG-03	30	4.8
	3/4	CLG-06	85	9

### 附件 Attachment :

型號 Model	安裝螺絲 Mounting bolts		O 型環 O-Ring			
CLT-03	M8 x 70L	4 支 piece	JIS B 2401-1B-P9	1 條 piece	JIS B 2401-1B-P9	2 條 piece
CLT-06	M10 x 100L	4 支 piece	JIS B 2401-1B-P14	1 條 piece	JIS B 2401-1B-P28	2 條 piece
CLG-03	M8 x 70L	4 支 piece	JIS B 2401-1B-P9	1 條 piece	JIS B 2401-1B-P9	2 條 piece
CLG-06	M10 x 100L	4 支 piece	JIS B 2401-1B-P14	1 條 piece	JIS B 2401-1B-P28	2 條 piece

### 圖形符號 Graphic symbol :

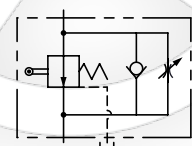

常開  
Normally Open  
CLG/CLT

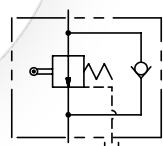

常閉  
Normally Closed  
CLG/CLT

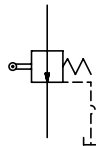

常開  
Normally Open  
LG/LT

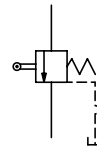

常閉  
Normally Closed  
LG/LT

# 流量控制閥 (減速閥附止回閥)

## FLOW CONTROL VALVE (Deceleration with check valve)

### CLT-03.06

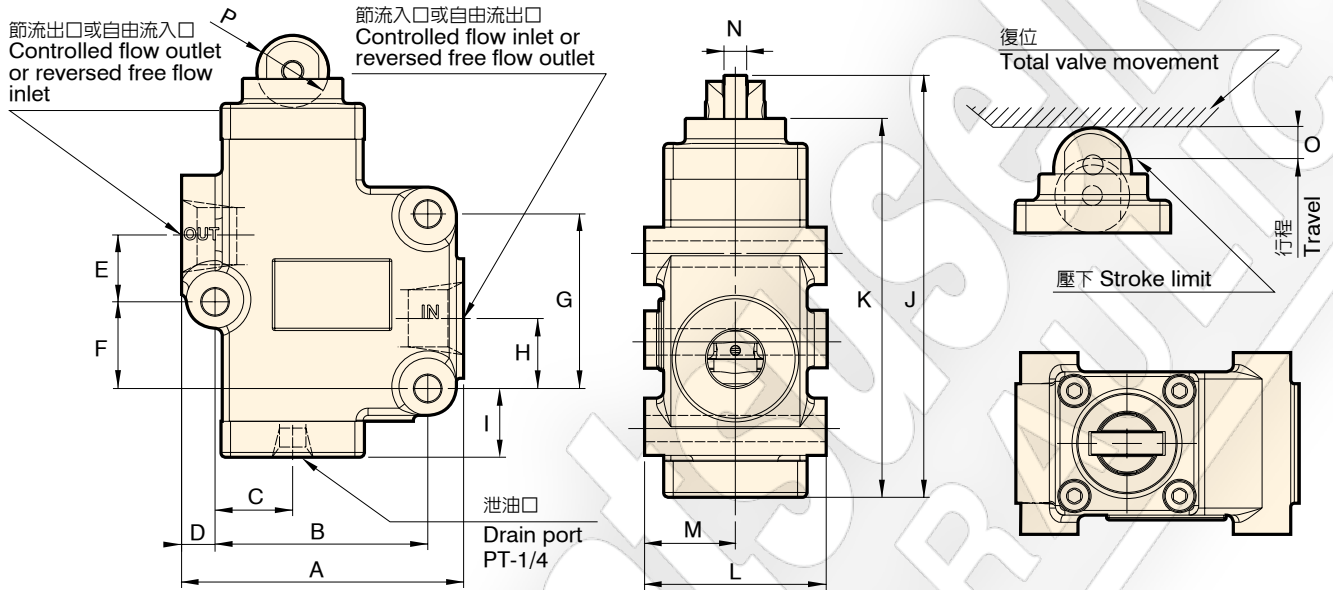

單位 Unit : mm

型號 Model	A	B	C	D	E	F	G	H	I	J	K	L	M	N	O	P
CLT-03	116	84	31	16	34	16	68	26	29	161	142	68	34	8	12	27
CLT-06	118	90	33	13.5	28	35	73	29	30	176.5	160	76	38	10	12	30

### CLG-03.06

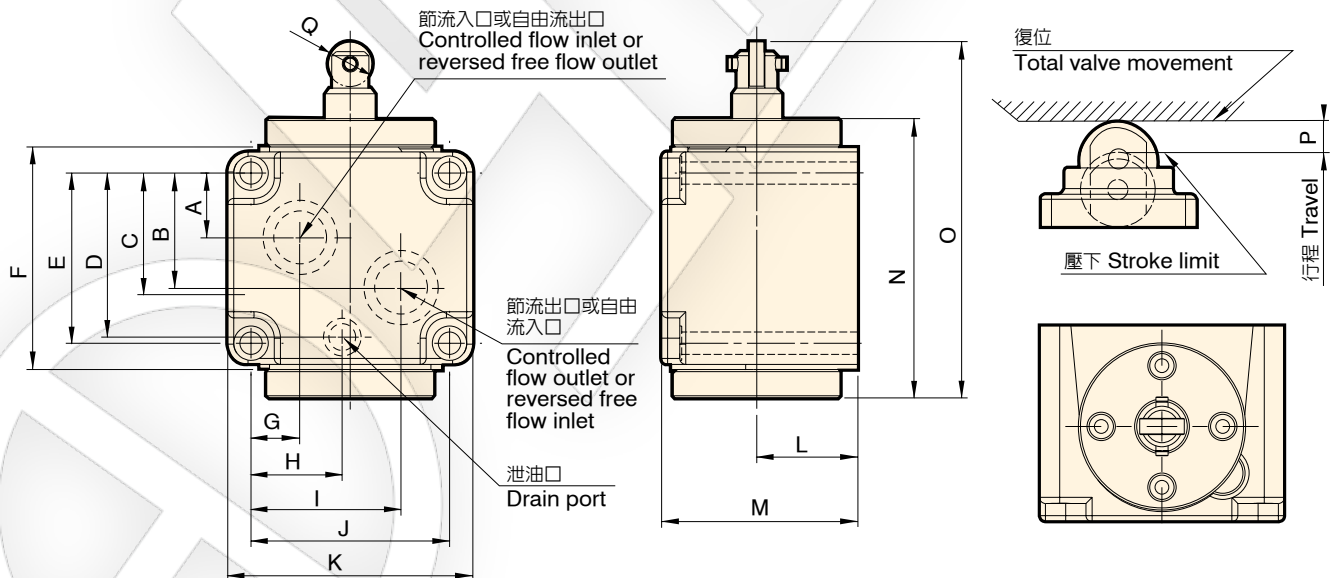

單位 Unit : mm

型號 Model	A	B	C	D	E	F	G	H	I	J	K	L	M	N	O
CLG-03	20	40	44	58	60	89	20	38	60	80	105	35	74	113	133
CLG-06	32	57	60	81	84	110	23.9	45	73.95	98	121	50	97	138.5	200

### 性能曲線圖 Performance curves

#### ■ 流量-壓力特性曲線圖

The characteristic curve chart of Flow vs. Pressure

使用油：黏度 Test fluid viscosity: 35mm<sup>2</sup>/s {cSt}

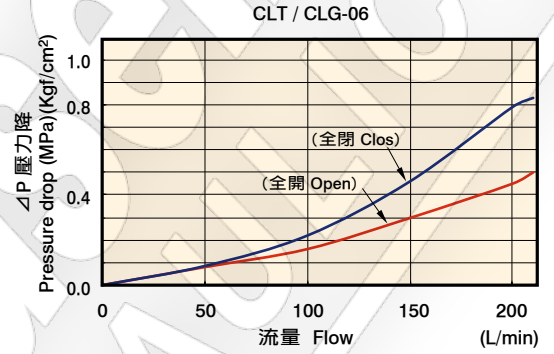
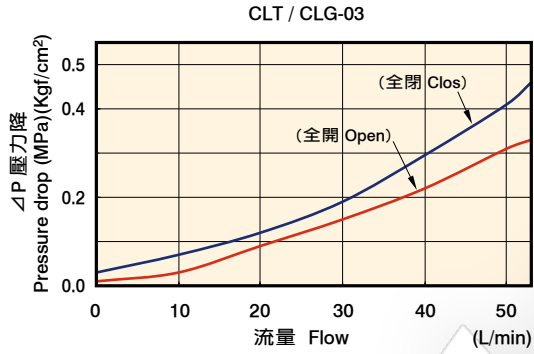

流量控制閥 減速閥附止回閥  
Flow Control Valve (Deceleration with check valve)

### CLT 出入油標示 CLT Inlet / outlet sign

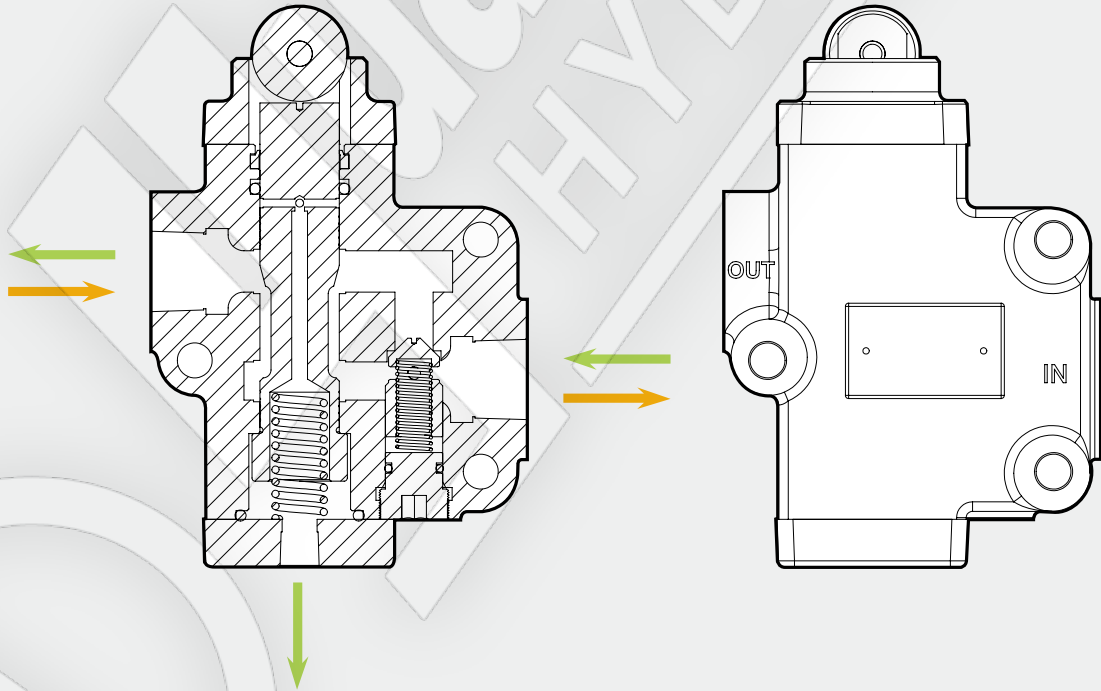

CLG 出入油標示 CLG Inlet / outlet sign

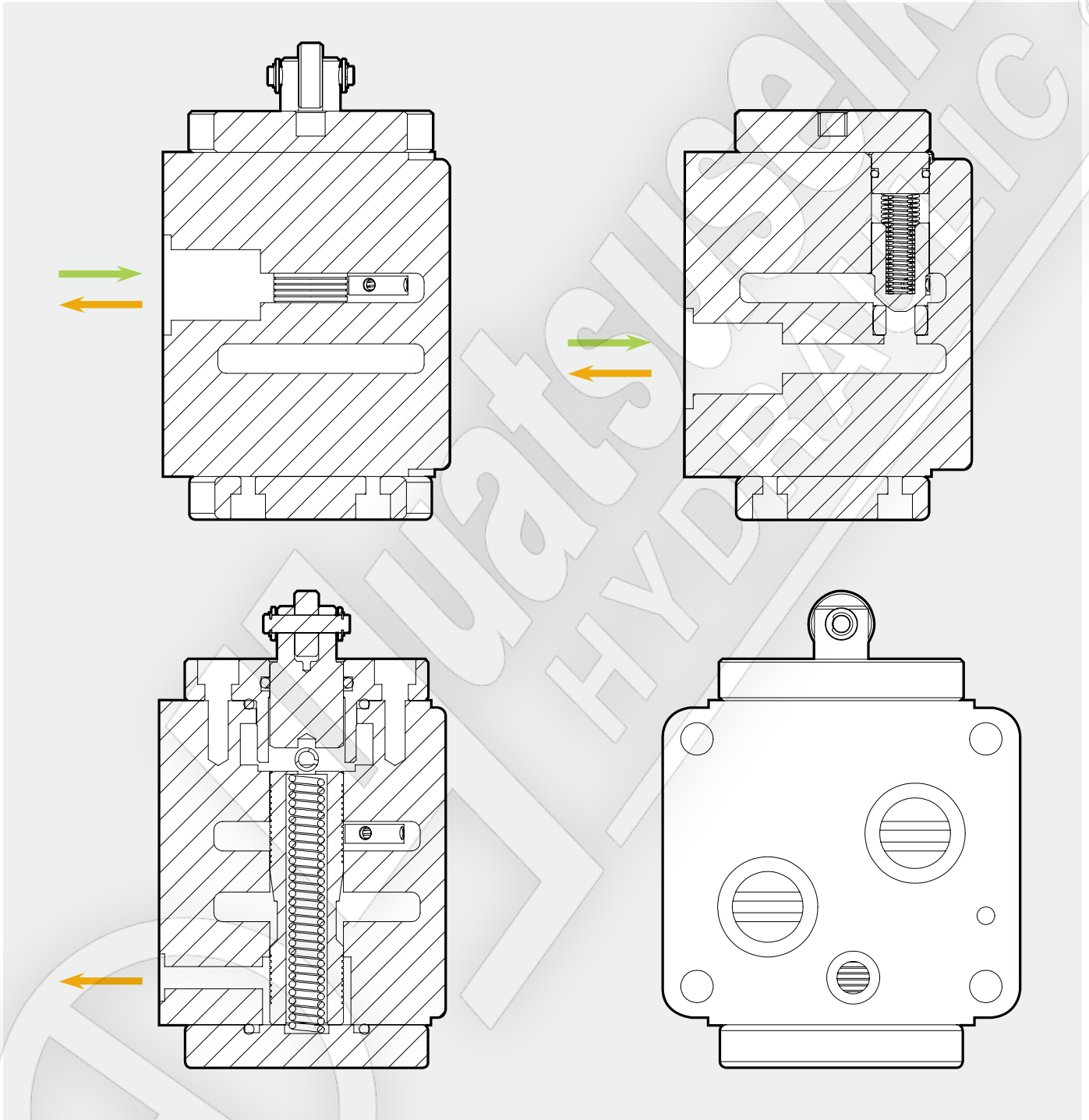

流量控制閥 減速閥附止回閥  
Flow Control Valve (Deceleration with check valve)

### 爆炸圖 How to order for a complete assembled valve

CLT-03.06

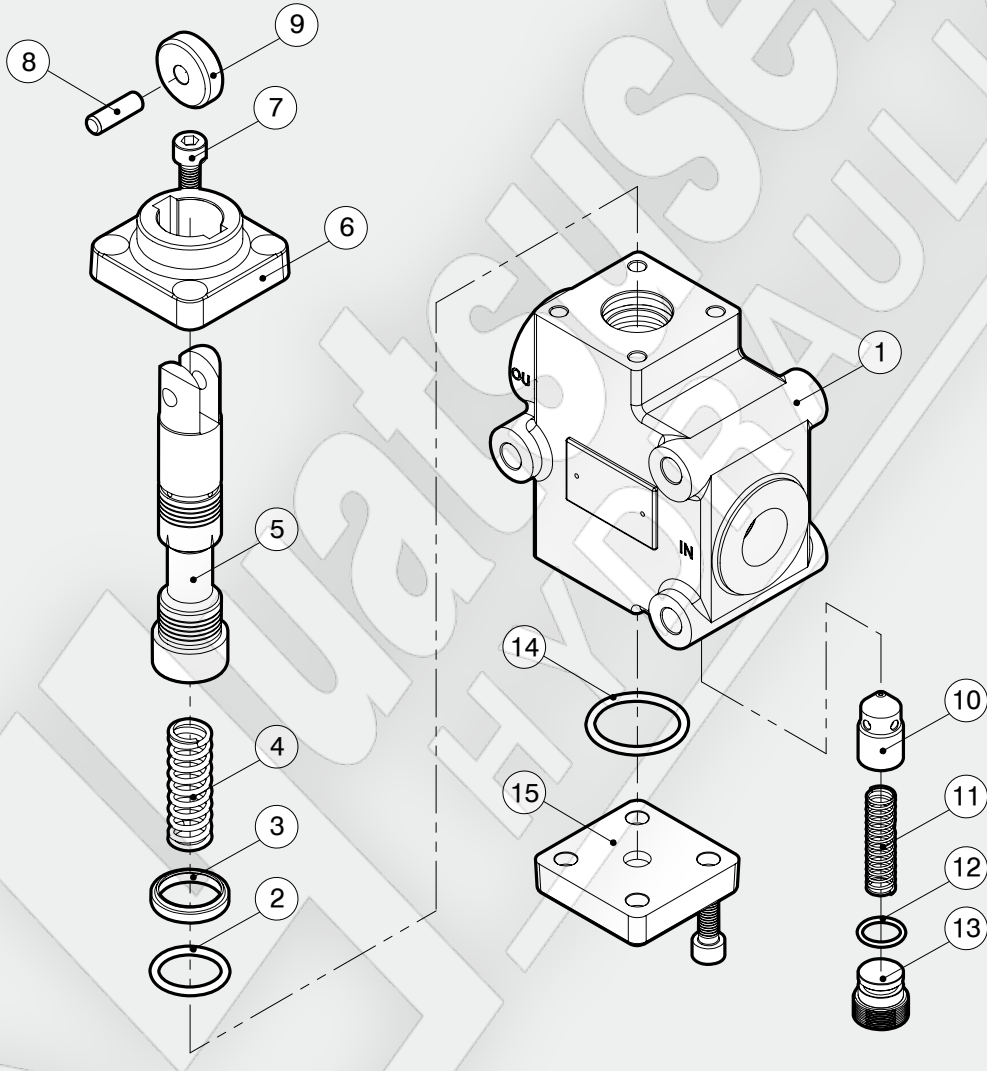

流量控制閥 減速閥附止回閥  
 Flow Control Valve (Deceleration with check valve)

項次編號 No.	品名 Name of parts	數量 Q
1	本體 Body	1
2	CLT-03 JIS B 2401-1A-P20	1
	CLT-06 JIS B 2401-1A-P25	1
3	CLT-03 SER-20	1
	CLT-06 SER-25	1
4	彈簧 Spring	1
5	心軸 Spool	1
6	閥蓋 Cover	1
7	M8 x 20L	8
8	鋼棒 Straight pin	1

項次編號 No.	品名 Name of parts	數量 Q
9	滾輪 Wheel	1
10	槍子閥 Check valve	1
11	彈簧 Spring	1
12	CLT-03 JIS B 2401-1A-P10A	1
	CLT-06 JIS B 2401-1A-P14	1
13	螺母 Nut	1
14	CLT-03 JIS B 2401-1A-P32	1
	CLT-06 JIS B 2401-1A-P34	1
15	底蓋 Cover	1

### 爆炸圖 How to order for a complete assembled valve

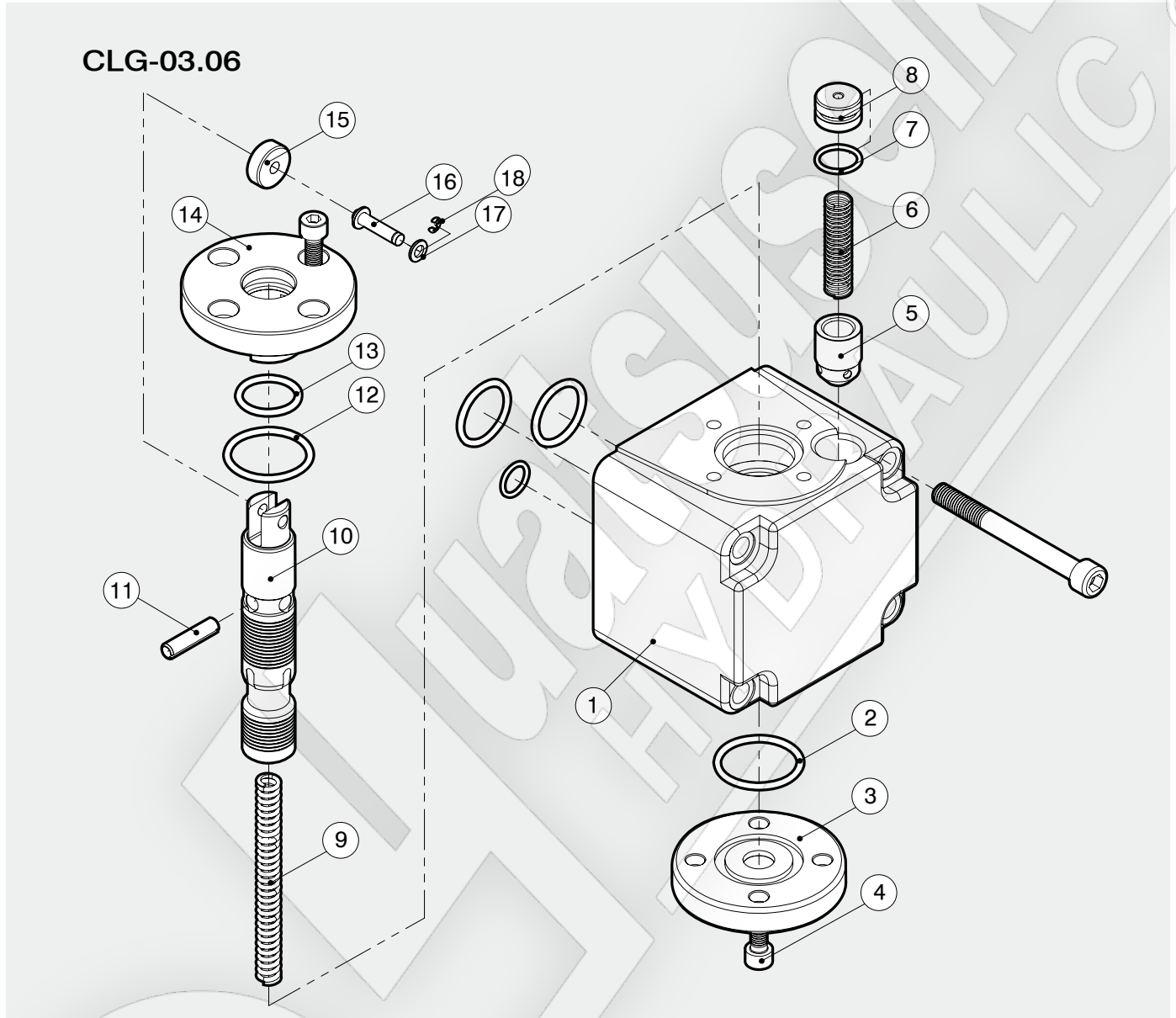

流量控制閥 減速閥附止回閥  
Flow Control Valve (Deceleration with check valve)

項次編號 No.	品名 Name of parts	數量 Q
1	本體 Body	1
2	CLG-03 JIS B 2401-1B-P32	1
	CLG-06 JIS B 2401-1B-P36	1
3	底蓋 Cover	1
4	CLG-03 M6 x 20L 下 Down	4
	CLG-06 M8 x 20L	8
5	槍子閥 Check valve	1
6	彈簧 Spring	1
7	CLG-03 JIS B 2401-1A-P12	1
	CLG-06 JIS B 2401-1A-P18	1
8	推桿 Push rod	1

項次編號 No.	品名 Name of parts	數量 Q
9	彈簧 Spring	1
10	心軸 Spool	1
11	彈簧插銷 Spring pin	1
12	CLG-03 JIS B 2401-1B-P32	1
	CLG-06 JIS B 2401-1B-P36	1
13	CLG-03 JIS B 2401-1A-P20	1
	CLG-06 JIS B 2401-1A-P25	1
14	閥蓋 Cover	1
15	滾輪 Wheel	1
14	鋼棒 Straight pin	1
15	墊片 Washer	1
16	E型扣 E-type	1